

## TEHNIČNI LIST - DIMENZIJE

### 13601: MINI HIDRAVLIČNI AGREGAT 380V AC (4 kW) - 8 cc - 12 lit/min - tank 40 lit

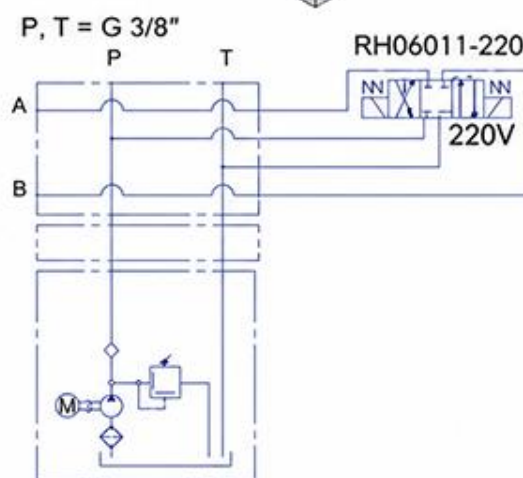
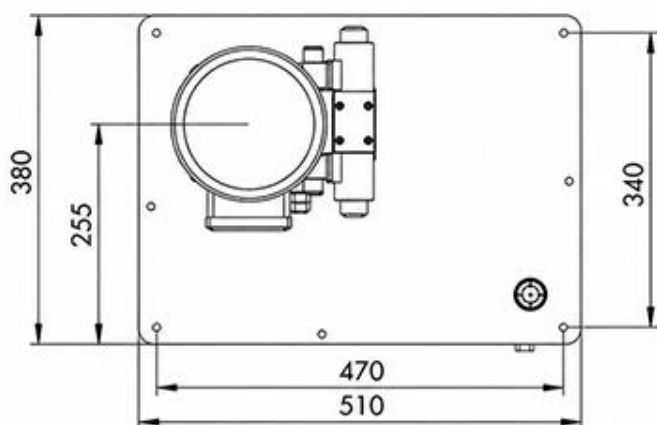
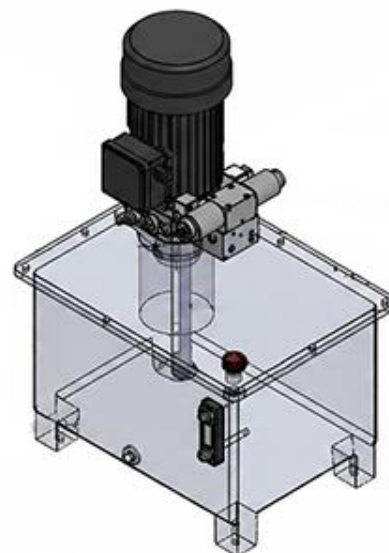
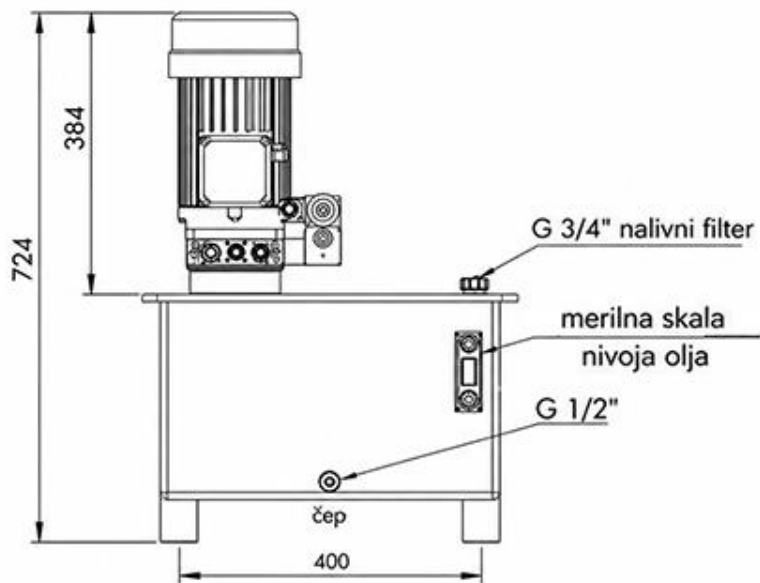

ŠIFRA	EL. NAPETOST (V)	MOČ MOTORJA (kW)	MAX. TLAK (bar)	PRETOK ČRPALKE (cc)	PROSTORNINA REZERVOARJA (l)	PRETOK AGREGATA (lit/min)	VRTLJAJI (vrt/min)
13601	380	4	120	8	40	12	1500

VEZANA SHEMA:

